

KOBELCO

Your competitive edge.

235SR Lc High & Wide

WT 60,638 lb

HP 143 SAE NET

BKT CAP .67-1.67 cu yd



High & Wide

SHORT RADIUS Hydraulic Excavator

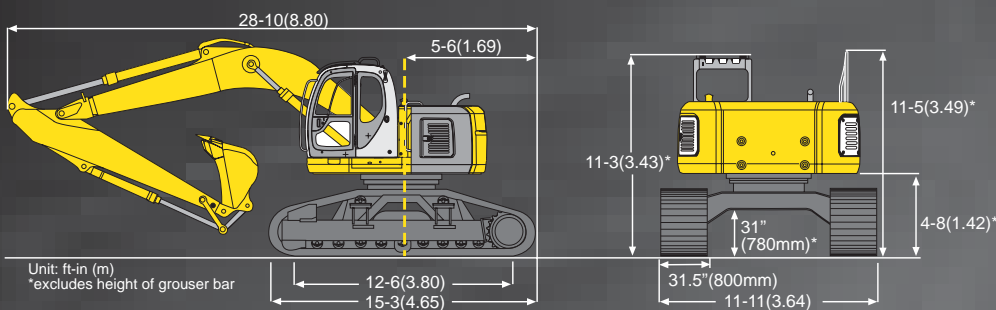

SPECIFICATIONS

235SR_{LC} High & Wide

PERFORMANCE

Bucket capacity (SAE heaped)	0.67~1.67 yd ³ (0.51~1.28 m ³)
Travel speed	3.3/2.0 mph (5.3/3.3 km/h)
Swing speed	11.0 rpm
Swing torque	58,267 lbs ft (79 kN•M)
Drawbar pulling force	52,920 lbs (23,400 kg)

WEIGHT

Operating weight	60,638 lbs (27,500 kg)
Ground pressure (800mm shoes)	6.25 psi (0.44 kg/cm ²)

ENGINE

Model	Mitsubishi 6D34-TE1
Type	Direct injection, water-cooled, 4-cycle diesel engine w/turbocharger
Power output	143 HP @ 2,000 RPM (SAE J1349)
Fuel tank	77 US gal (290 liters)

HYDRAULIC SYSTEM

Pump	2 variable displacement
Max discharge flow	2 x 53 US gal/min (2 x 200 L/min)
Max discharge pressures:	
Boom, arm & bucket	4,980 psi (350 kg/cm ²)
Power boost	5,475 psi (385 kg/cm ²)
Propel circuit	4,980 psi (350 kg/cm ²)
Control circuit	710 psi (50 kg/cm ²)
Swing circuit	4,050 psi (285 kg/cm ²)
Control valves	6 spool
Hydraulic capacity: system/tank	61/33 US gal (230/125 liters)

WORKING RANGES

Unit: ft-in (m)

ATTACHMENT	9-8	(2.94)
Max digging reach	32-4	(9.85)
Max digging reach at ground level	31-5	(9.58)
Max digging depth*	20-9	(6.20)
Max digging height*	38-4	(11.68)
Max dumping clearance*	28-11	(8.82)
Min dumping clearance*	11-9	(3.58)
Max vertical wall digging depth*	18-8	(5.68)
Min front swing radius	6-3	(1.91)
Horiz. digging stroke at ground level	17-7	(5.37)
Digging depth for 8' (2.4 m) flat bottom	20-1	(6.13)
Bucket capacity SAE heaped-yd ³ (m ³)	.67~1.67	(.51~1.28)

* Excludes height of grouser bar.

DIGGING FORCE

Unit: lb (kg)

ARM LENGTH ft-in (m)	9-8	(2.94)
Bucket digging force †	30,000	(13,600)
Arm crowding force †	23,150	(10,500)

† Power Boost Engaged

- A Reach swing centerline to bucket hook
- B Bucket hook height above/below ground
- C Lifting capacities in pounds and kilograms
- Max discharge pressure: 5,467 psi (385 kg/cm²)
- Track shoe: 31.5" (800mm) Triple grouser

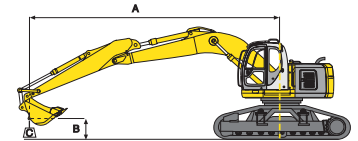

LIFTING CAPACITIES



Rating over front



Rating over side/ 360 degrees

A		235SR _{LC} High & Wide Arm: 9'8" (2.94 m) Bucket: 1.05 cu yd (0.80 m ³) SAE heaped - 1,410 lb (640 kg)											
		5' (1.5 m)		10' (3.0 m)		15' (4.6 m)		20' (6.1 m)		25' (7.6 m)			
B	C												
		30' (9.1 m)	lb					*9,180	*9,180				
	kg					*4,160	*4,160						
25' (7.6 m)	lb					*10,090	*10,090	*9,070	*9,070				
	kg					*4,580	*4,580	*4,110	*4,110				
20' (6.1 m)	lb					*11,290	*11,290	*10,860	*10,860	*6,100	*6,100		
	kg					*5,120	*5,120	*4,920	*4,920	*2,770	*2,770		
15' (4.6 m)	lb	*32,640	*32,640	*18,650	*18,650	*14,300	*14,300	*12,220	*12,220	*10,470	10,400		
	kg	*14,800	*14,800	*8,460	*8,460	*6,480	*6,480	*5,540	*5,540	*4,750	4,710		
10' (3.0 m)	lb			*29,400	*29,400	*18,330	*18,330	*14,100	*14,100	*11,950	10,110		
	kg			*13,330	*13,330	*8,310	*8,310	*6,390	*6,390	*5,410	4,580		
5' (1.5 m)	lb			*17,380	*17,380	*21,700	21,520	*15,830	13,800	*12,750	9,820		
	kg			*7,880	*7,880	*9,840	9,760	*7,170	6,260	*5,780	4,450		
Ground Level	lb	*10,320	*10,320	*20,840	*20,840	*23,170	20,840	*16,790	13,400	*13,110	9,610		
	kg	*4,680	*4,680	*9,450	*9,450	*10,510	9,450	*7,610	6,070	*5,940	4,360		
-5' (-1.5 m)	lb	*18,290	*18,290	*29,010	*29,010	*22,670	20,640	*16,570	13,240	*10,990	9,570		
	kg	*8,290	*8,290	*13,150	*13,150	*10,280	9,360	*7,510	6,000	*4,980	4,340		
-10' (-3.0 m)	lb	*27,080	*27,080	*28,650	*28,650	*20,140	*20,140	*14,570	*13,360				
	kg	*12,280	*12,280	*12,990	*12,990	*9,130	*9,130	*6,610	*6,060				
-15' (-4.6 m)	lb			*20,460	*20,460	*14,340	*14,340						
	kg			*9,270	*9,270	*6,500	*6,500						

NOTE: Due to our policy of continual product improvement, all designs and specifications are subject to change without advance notice.

KOBELCO

Your competitive edge.

Bulletin No. 235SRHW-US-102

Headquarters & Manufacturing

501 Richardson Rd.
Calhoun, Georgia 30701 USA
Phone: 706.629.5572 Fax: 706.629.3952

Sales & Product Support Offices

12755 S. Kirkwood
Stafford, Texas 77477 USA
Phone: 281.240.4800 Fax: 281.240.4906

Notes:

1. Do not attempt to lift or hold any load that exceeds these rated values at their specified load radii and heights.
2. Lifting capacities assume a machine standing on a level, firm, and uniform supporting surface. Operator must make allowance for job conditions such as soft or uneven ground, out of level conditions, side loads, sudden stopping of loads, hazardous conditions, inexperienced personnel, weight of various other buckets, lifting slings, attachments, etc.
3. Ratings calculated at bucket lift hook.
4. The previous rated loads are in compliance with SAE Hydraulic Excavator Lift Capacity Standard J 1097. They do not exceed 87% of hydraulic lifting capacity or 75% of tipping load. Rated loads marked with an asterisk (*) are limited by hydraulic capacity rather than tipping load.
5. Operator should be fully acquainted with the operator's manual before operating this machine. Rules for safe operation of equipment should be followed at all times.
6. Capacities apply only to the machine as originally manufactured and normally equipped by KOBELCO America Inc.